



M18 Photoelectric Sensors - S51 Series

Cost-effective & Versatile Photoelectric Sensor

The S51 series offers a cost-effective solution in M18 photoelectric sensors, with a wide range of functions and operating distances. S51 sensors are available with either axial or radial 90° optics. In both cases, the optic head and lenses do not project beyond the external 18mm diameter of the sensor housing. The diffuse-proximity model has a 10cm fixed operating range with a wide emission spectrum. Also available is a version with a 1 - 40cm adjustable operating range.

Standard retro-reflective models have an operating range up to 4m. The polarized retro-reflective models, used for reliable

detection of reflective objects, are fitted with a sensitivity adjustment and have a 3.5m operating range. The through-beam models, used for longer operating distances, reach 18 meters.

With cable or M12 connector versions and PNP or NPN output, the S51 sensors provide a 3-wire connection configuration in compliance with the EN60947-5-2 standard. The normally open output is activated in light mode in proximity models and in dark mode in retro-reflective models. The output mode can be inverted using the dark/light selection input wire provided, making these extremely versatile sensors.

Dimensions (mm)

Retro-reflective, Short Diffused, Through-beam Emitter Axial Optic Models

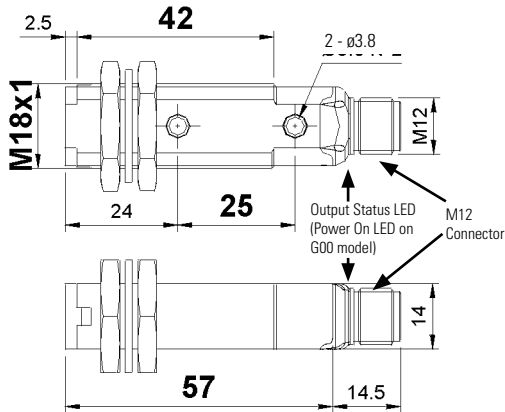

Radial Optic Models

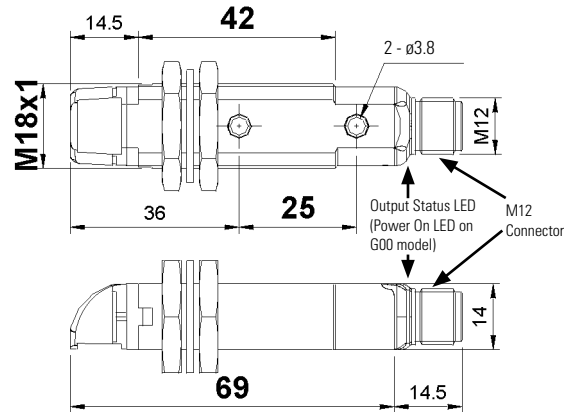

Polarized Retro-reflective, Long Diffused, Through-beam Receiver Axial Optic Models

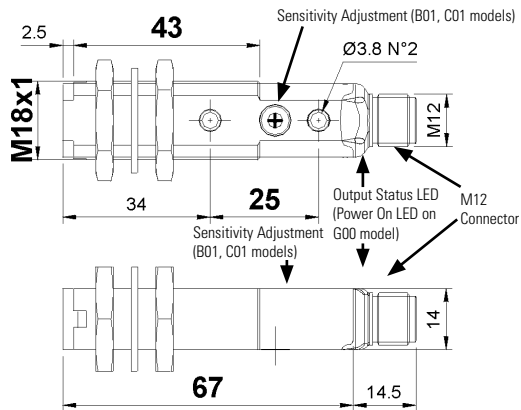

Radial Optic Models

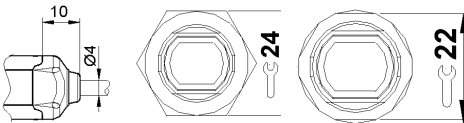
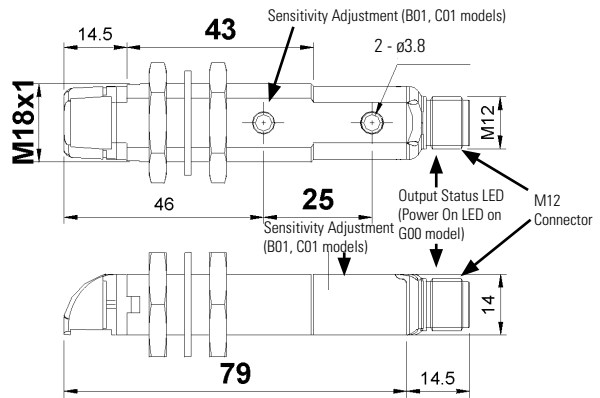

Connections

Through-beam

BROWN	1	+	10 ... 30 Vdc		
WHITE	2		TEST +	2	1
BLACK	4		TEST -	3	4
BLUE	3	-	0 V		

Retro-reflective, Polarized Retro-reflective, Long Diffused, Short Diffused, Through-beam

BROWN	1	+	10 ... 30 Vdc		
WHITE	2		LIGHT/DARK	2	1
BLACK	4		NO OUTPUT	3	4
BLUE	3	-	0 V		

Indicators & Settings



Specifications

Long Diffuse Proximity Operating Distance	1 - 40cm (radial version 30 cm)
Short Diffuse Proximity Operating Distance	0 - 10cm (radial version 8 cm)
Retro-reflective Operating Distance	0.1 - 4m on R2 (radial version 3 m) on R5
Polarized Retro-reflective Operating Distance	0.1 - 3m on R2 (radial version 2.5 m) on R5
Through-beam Operating Distance	0 - 18m (radial version 15 m)
Power Supply	10 - 30V DC ¹
Ripple	≤ 2 Vpp
Current Draw	≤ 35 mA
Light Emission ²	Infrared LED 880 nm Red LED 650 nm (B01 models)
Setting	Sensitivity adjustment (B01, C01 models) ³
Indicators	Yellow OUTPUT LED (excl. G00 models) Green POWER LED (G00 models)
Output Type	NPN or PNP versions
Output Current	≤ 100mA
Saturation Voltage	≤ 2V
Response Time	1ms 4ms (F00 mod.)
Switching Frequency	≤ 500Hz ≤ 120Hz (F00 mod.)
Operating Mode	dark/light selectable ⁴
Auxiliary Functions	Test + and Test - (G00 mod.) ⁵
Connection	2m ø4 mm cable ⁶ M12 4-pole connector ⁷
Electrical Protection	Class 2
Mechanical Protection	IP67
Protection Devices	A, B ⁸
Housing Material	PBT
Lens Material	PMMA
Weight	25g max. (S51-PA/PR-5), 75g max. (S51-PA/PR-2)
Operating Temperature	-25 to +55°C
Storage Temperature	-25 to +70°C
Reference Standard	EN60947-5-2, UL 508



1. Limit values.
2. Average life of 100,000 hrs with $T_a = +25^\circ\text{C}$.
3. 270° single-turn sensitivity adjustment.
4. With L/D input not connected the proximity models function in the light mode and the retro-reflective and through-beam models in the dark mode; the light mode can be selected by connecting the L/D input to +V DC, the dark mode connecting it to 0V DC.
5. Emitter off with Test+ connected to +V DC and Test- to 0V DC.
6. PVC, 4 x 0.14mm²
7. M12 connector compatible with quick connection systems.
8. A - reverse polarity protection
B - overload and short-circuit protection

Connector Cables

Appearance	Number of Core Wires	Type & Length	Use with	Part No.
	4	Straight, 5m	S51, S60, S62	CS-A1-02-G-05
	4	Right angle, 5m		CS-A2-02-G-05

Detection Diagrams

Long Diffused

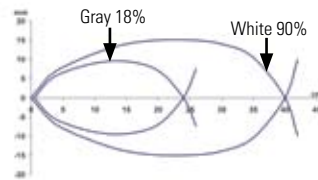

Short Diffused

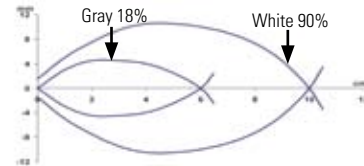

Short Diffuse Proximity

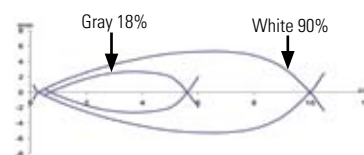

Retro-reflective

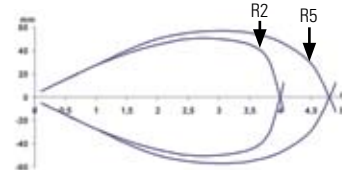

Polarized Retro-reflective

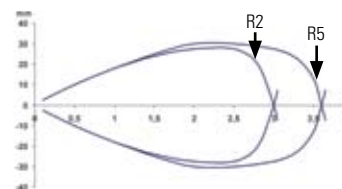

Through-beam

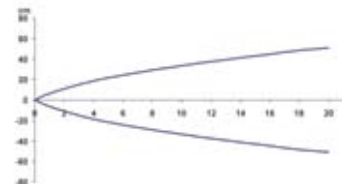

Part Numbers

Axial	Optic Function	Connection	Output	Part Number
		2m cable	PNP	S51-PA-2-A00-PK
			NPN	S51-PA-2-A00-NK
		M12 connector	PNP	S51-PA-5-A00-PK
			NPN	S51-PA-5-A00-NK
		2m cable	PNP	S51-PA-2-B01-PK
			NPN	S51-PA-2-B01-NK
		M12 connector	PNP	S51-PA-5-B01-PK
			NPN	S51-PA-5-B01-NK
		2m cable	PNP	S51-PA-2-C01-PK
		M12 connector	PNP	S51-PA-5-C01-PK
			NPN	S51-PA-5-C01-NK
			2m cable	PNP
	NPN			S51-PA-2-C10-NK
	M12 connector		PNP	S51-PA-5-C10-PK
			NPN	S51-PA-5-C10-NK
		2m cable	PNP	S51-PA-2-F00-PK
			NPN	S51-PA-2-F00-NK
		M12 connector	PNP	S51-PA-5-F00-PK
NPN			S51-PA-5-F00-NK	
Emitter	2m cable	–	S51-PA-2-G00-XG	
	M12 connector	–	S51-PA-5-G00-XG	
Radial	Optic Function	Connection	Output	Part Number
		2m cable	PNP	S51-PR-2-A00-PK
			NPN	S51-PR-2-A00-NK
		M12 connector	PNP	S51-PR-5-A00-PK
			NPN	S51-PR-5-A00-NK
		2m cable	PNP	S51-PR-2-B01-PK
			NPN	S51-PR-2-B01-NK
		M12 connector	PNP	S51-PR-5-B01-PK
			NPN	S51-PR-5-B01-NK
		2m cable	PNP	S51-PR-2-C01-PK
		M12 connector	PNP	S51-PR-5-C01-PK
			NPN	S51-PR-5-C01-NK
			2m cable	PNP
	NPN			S51-PR-2-C10-NK
	M12 connector		PNP	S51-PR-5-C10-PK
			NPN	S51-PR-5-C10-NK
		2m cable	PNP	S51-PR-2-F00-PK
			NPN	S51-PR-2-F00-NK
		M12 connector	PNP	S51-PR-5-F00-PK
NPN			S51-PR-5-F00-NK	
Emitter	2m cable	–	S51-PR-2-G00-XG	
	M12 connector	–	S51-PR-5-G00-XG	

Operating Distance

Retro-reflective

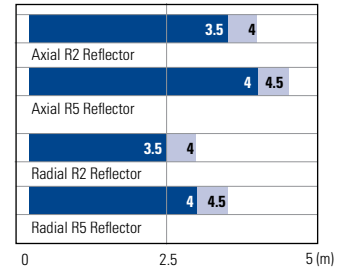

Short Diffused

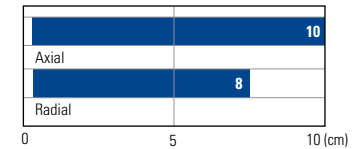

Polarized Retro-reflective

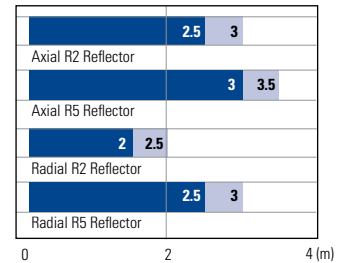

Through-beam

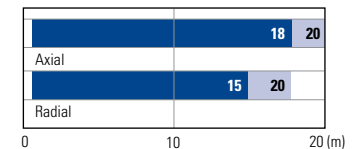

Long Diffuse

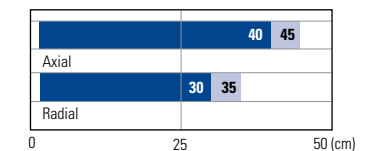

■ Recommended operating distance
 ■ Maximum operating distance